

40Gbps QSFP+ 40KM ER4 SMF

SLQS-40G-ER4



Overview

The SLQS-40G-ER4 is a 4x10G hot pluggable optical transceiver. The Sourcelight Technology enables the integration of 4 transmitters, 4 receivers and an optical MUX/DeMUX into a small form factor package that delivers a 40Gbps data link in a compact QSFP footprint.

The optical connectivity is based on two SMF LC connectors, one for Tx and one for Rx. The Tx and Rx each consist of 4 10GB/s CWDM channels, whose wavelengths are in the 1300nm range. The QSFP-ER transceiver is designed for applications based on the IEEE 802.3ba 40BASE-ER4 standard of up to 40km reach.

Features

- ◆ Compliant with 40G Ethernet IEEE802.3ba and
- ◆ 40GBASE-ER4 Standard
- ◆ QSFP+ MSA compliant
- ◆ Compliant with QDR/DDR Infiniband data rates
- ◆ Up to 11.2Gb/s data rate per wavelength
- ◆ 4 CWDM lanes MUX/DEMUX design
- ◆ Up to 40km reach over standard single mode fiber
- ◆ Operating case temperature 0°C to +70°C
- ◆ 3.5V power supply
- ◆ RoHS 6 compliant (lead free)

Applications

- ◆ 40GBASE-ER4 40G Ethernet links
- ◆ Infiniband QDR and DDR interconnects
- ◆ Client-side 40G Telecom connections

Ordering Information

Part Number	Product Description
SLQS-40G-ER4	QSFP+ ER4 1270/1290/1310/1330nm 40km on Single mode Fiber (SMF)

Datasheet
Absolute Maximum Ratings

Parameter	Symbol	Min	Max	Unit
Supply Voltage	V _{CC-Tx/V_{CC-Rx/V_{CC1}}}	-0.5	3.6	V
Storage Temperature Range	T _{STG}	-40	+85	°C
Maximum Average Input Optical Power per lane (Damage Threshold)	P _{IN}	3.8		dBm
Relative Humidity	RH	0to 85% (non-condensing)		

Operating Conditions

Parameter	Symbol	Min	Max	Unit
Supply Voltage	V _{CC-Tx/V_{CC-Rx/V_{CC1}}}	3.1	3.5	V
Operating Case temperature	T _{CASE}	0	70	°C
Power Consumption	P _{DISS}		3.5	W
SMF Link Length	L _{KM}		40	km

High Speed Electrical Specifications

Parameter	Min	Typical	Max	Units
General				
Supply Voltage	3.1	3.3	3.5	Volts
Supply Current			1.1	Amps
Maximum Power Consumption			3.5	Watts
Maximum Power Consumption – LP Mode			1.5	Watts
Signaling Speed Per Channel		10.3125		Gb/s
Signaling Speed Operating Range		±100		ppm
Transmitter				
Transmitter Differential Input Impedance	90	100	110	ohms
Transmitter Differential Input Voltage	0.2		1.6	Volts
Receiver				
Differential Output impedance	90	100	110	ohms
Differential output voltage	300		850	mV

Optical Characteristics

Transmitter Specifications

Parameter	Min	Typical	Max	Unit
Lane Wavelength Range	1264.5 1284.5 1304.5 1324.5	1271 1291 1311 1331	1277.5 1297.5 1317.5 1337.5	nm
Data Rate Per Lane		10.3125		Gb/s
Average Optical power per lane	-3.7		4.5	dBm
Total Average Launch power			10.5	dBm
Optical Modulation Amplitude (OMA), each lane	-0.7		5	dBm
Extinction Ratio	5.5			dB
Difference in launch power between any two lanes			7	dB
Relative Intensity Noise (RIN)			-128	dB/Hz
Launch Power in OMA minus TDP, each lane	-1.5			dBm
Transmitter and dispersion penalty (TDP), each lane			2.6	dB
Side-Mode Suppression Ratio (SMSR)	30			dB
Average Launch Power per lane @ TX off state			-30	dBm
Transmitter Reflectance			-12	dB
Optical return loss tolerance			20	dB
Transmitter Eye Mask definition: X1, X2, X3, Y1, Y2, Y3	Compliant with 802.3ba standard {0.25, 0.4, 0.45, 0.25, 0.28, 0.4}			
Eye Mask Criteria	5% mask margin over specified ranges of temperature, voltage and power supply noise at end of life.			

Receiver Specifications

Parameter	Min	Typical	Max	Unit
Lane Wavelength Range	1264.5 1284.5 1304.5 1324.5	1271 1291 1311 1331	1277.5 1297.5 1317.5 1337.5	nm
Damage Threshold			3.8	dBm
Average Receive Power, each lane	-20.2		-1.5	dBm
Receive Power, each lane (OMA)			-1	dBm
Difference in Receive Power between any two lanes (OMA)			7.0	dB
Receiver Reflectance			-26	dB

Datasheet

Receiver Sensitivity (OMA) per lane (10.3125Gb/s @ PRBS 2 ³¹ -1 and BER=10 ⁻¹²)			-18	dBm
Receiver 3 dB electrical upper cutoff frequency, each lane			12.3	GHz
Stressed Receiver Sensitivity OMA), each lane			-15.8	dBm
Conditions of stressed receiver sensitivity tests	Vertical eye closure penalty, each lane	2.2		dB
	Stressed eye jitter per lane	0.3		UI
RX_LOS_Assert Min/Max (dBm)		-35		dBm
RX_LOS_De-Assert Max(dBm)			-20	dBm
RX_LOS_Hysteresis (dBm)		0.5		dB

Functional Block Diagram

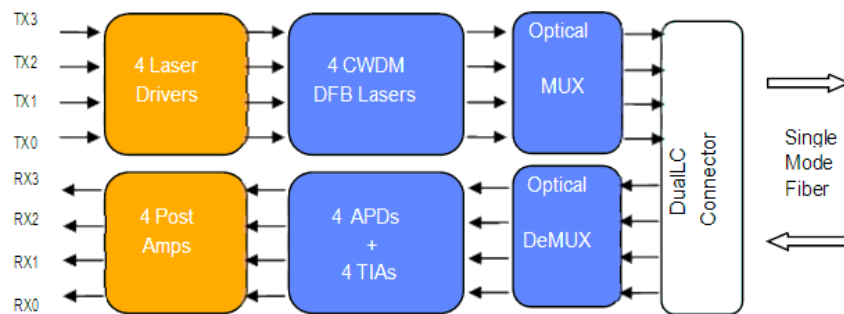

Figure1. Functional Block Diagram

Recommended Host Board Power Supply Filtering

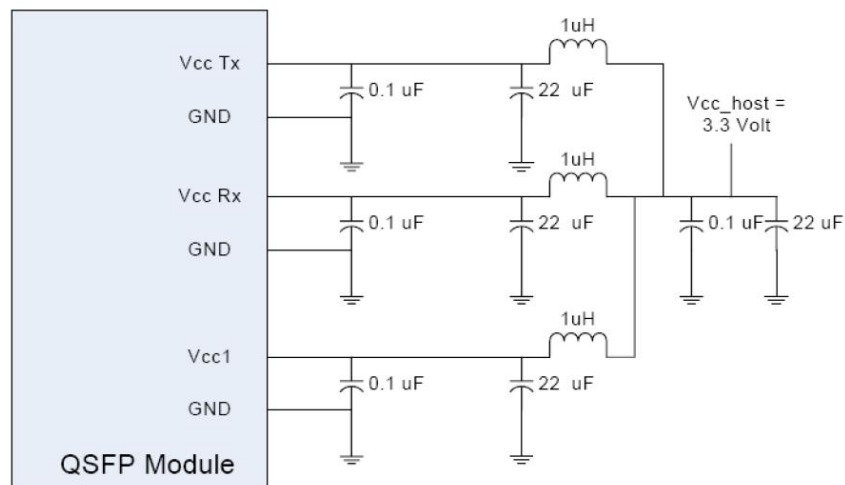

Figure2. QSFP voltage supply and filtering scheme

QSFP Edge Connector and Pinout Description

The electrical interface to the transceiver is a 38-pin edge connector. The 38-pins provide high speed data, low speed monitoring and control signals, I²C communication, power and ground connectivity. The top and bottom views of the connector are provided below, as well as a table outlining the contact numbering, symbol and full description.

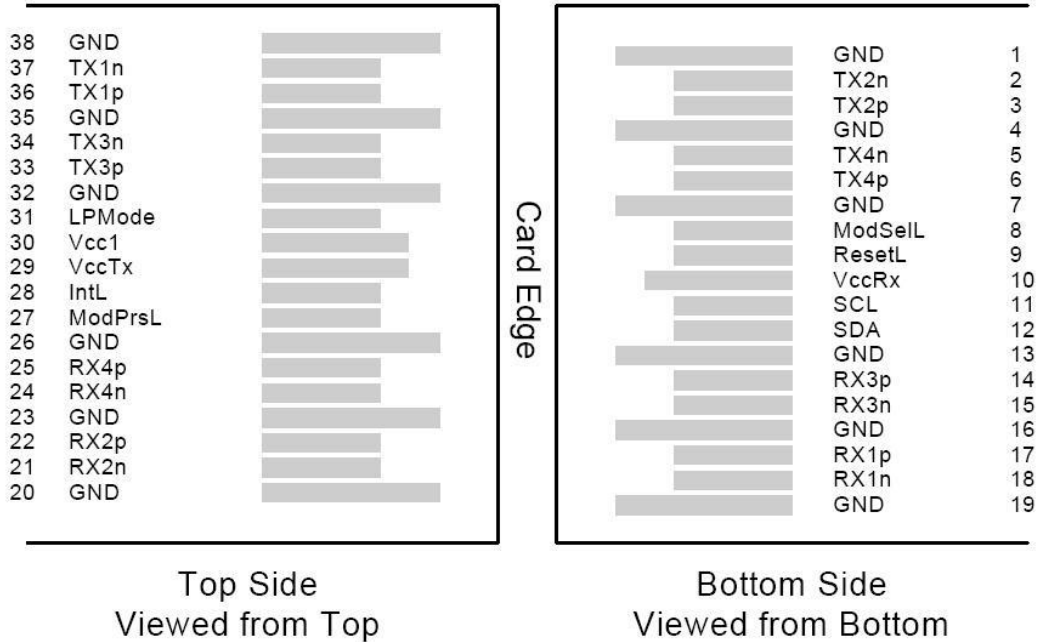

Figure3. QSFP Edge Connector and Pinout Description

QSFP Transceiver Pinout

Pin	Logic	Symbol	Name/Description	Ref.
1		GND	Ground	1
2	CML-I	Tx2n	Transmitted Inverted Data Input	3
3	CML-I	Tx2p	Transmitted Non-inverted Data Input	3
4		GND	Ground	1
5	CML-I	Tx4n	Transmitted Inverted Data Input	3
6	CML-I	Tx4p	Transmitted Non-inverted Data Input	3
7		GND	Ground	1
8	LVTTL-I	ModSeiL	Module Select	3
9	LVTTL-I	ResetL	Module Reset	3
10		Vcc Rx	+3.3 VDC Receiver Power Supply	2
11	LVC MOS-I/O	SCL	Serial Clock for I ² C Interface	3
12	LVC MOS-I/O	SDA	Serial Data for I ² C Interface	3
13		GND	Ground	1
14	CML-O	RX3p	Receiver Non-inverted Data Output	3
15	CML-O	RX3n	Receiver Inverted Data Output	3

Datasheet

16		GND	Ground	1
17	CML-O	RX1p	Receiver Non-inverted Data Output	3
18	CML-O	RX1n	Receiver Inverted Data Output	3
19		GND	Ground	1
20		GND	Ground	1
21	CML-O	RX2n	Receiver Inverted Data Output	3
22	CML-O	RX2p	Receiver Non-inverted Data Output	3
23		GND	Ground	1
24	CML-O	RX4n	Receiver Inverted Data Output	3
25	CML-O	RX4p	Receiver Non-inverted Data Output	3
26		GND	Ground	1
27	LVTTTL-O	ModPrsL	Module Present	3
28	LVTTTL-O	IntL	Interrupt	3
29		Vcc Tx	+3.3 VDC Transmitter Power Supply	2
30		Vcc1	+3.3 VDC Power Supply	2
31	LVTTTL-I	LPMODE	Low Power Mode	3
32		GND	Ground	1
33	CML-I	TX3p	Transmitted Non-inverted Data Input	3
34	CML-I	TX3n	Transmitted Inverted Data Input	3
35		GND	Ground	1
36	CML-I	TX1p	Transmitted Non-inverted Data Input	3
37	CML-I	TX1n	Transmitted Inverted Data Input	3
38		GND	Ground	1

Mechanical Dimensions

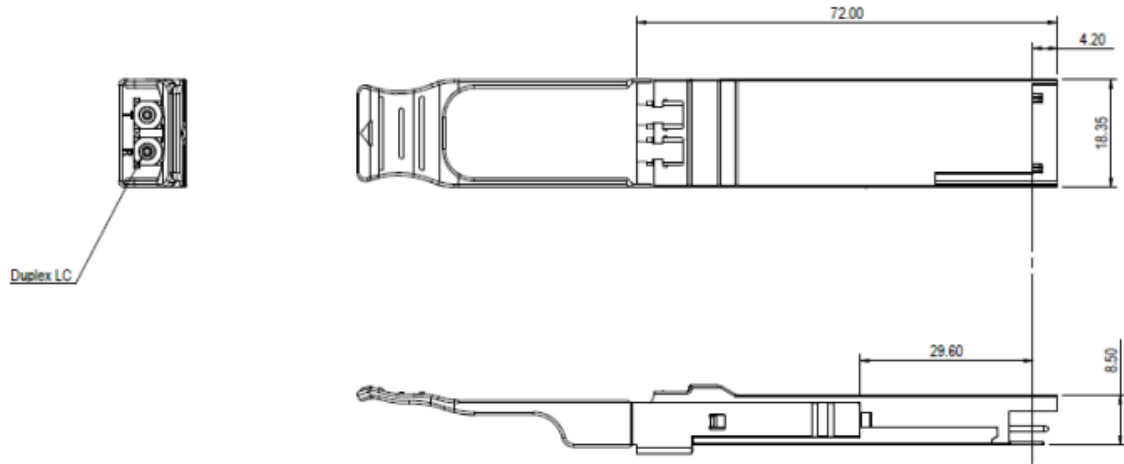

Figure4. Mechanical Specifications

Regulatory Compliance

Requirement	Standard
Electromagnetic Interference (EM)	Compliant to Class B requirements for FCC Part15 and CISPR 22
RF Immunity (RFI)	Compliant to EN/IEC 61000-4-3 and GR-1089-CORE Issue 4
Electrostatic Discharge (ESD)	Compliant to EN/IEC 61000-4-2 and GR-1089-CORE Issue 4 JEDEC JESD22-A114-B (2Kv limit)
Eye Safety	Compliant to Class 1M Laser Device per IEC60825-1
Lead Free Requirement (RoHS)	Compliant to 2002/95/EC RoHS 6/6 Directive

Shenzhen Sourcelight Technology Co., Ltd

Sourcelight Technology reserves the right to make changes to or discontinue any optical link product or service identified in this document without notice in order to improve design and/or performance. If you have any question regarding this specification sheet, please contact our sales representative or send email to sales@sourcelight.com.cn